

# Special High Grade Zinc (SHG) 99.995%

## Technical Datasheet

### Uses

Nyrstar Overpelt Z1 slab, is a LME-approved brand, conforming to the specifications covering quality, shape and weight as defined by the special contract rules of the LME and SHFE Standards.

### Chemical specification

Chemical specification	Guaranteed analysis	Typical SHG analysis (2016)
Pb	≤ 0.003%	0.0017%
Cd	≤ 0.003%	0.0002%
Fe	≤ 0.002%	0.0005%
Sn	≤ 0.001%	0.0001%
Cu	≤ 0.001%	0.0005%
Al	≤ 0.001%	0.0002%
Total of 6 elements above Zn, min.	≤ 0.005%	0.0032%
	99.995%	

### Standards

Standard	Grade
European EN1179:2003 International ISO752:2004 Japanese JIS H2107-1999 American ASTM B6-12	Z1 ZN-1 Highest Pure Zinc Metal LME (Z12002)

### Physical data

Physical property	Unit	Value
Density solid	kg/dm <sup>3</sup>	7.14
liquid (@ 419°C)	kg/dm <sup>3</sup>	6.62
Melting point	°C	419
Superficial tension (@ 450°C)	N/m	0.78
Melting enthalpy	kJ/kg	100
Thermal capacity solid	J/kg K	460
liquid	J/kg K	628

### Available shapes/package

Shape/package	Nominal weight (in kg)	Dimensions (in mm)
Slab	25	470 x 235 x 40
Slab bundle (40 slabs per bundle)	1000 ± 100	940 x 470 x 442

# Special High Grade Zinc (SHG) 99.995%

## Technical Datasheet

Slab (Ingot and feet)

Nominal mass 25 kg  
Dimensions 470 x 235 x 40

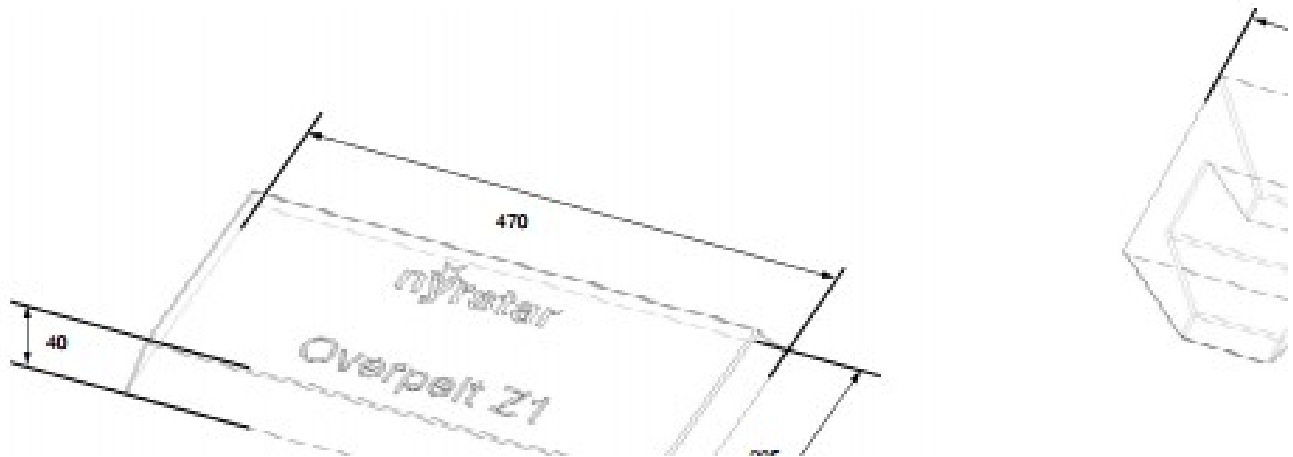

Slab bundle (40 slabs per bundle)

Nominal mass 1000 ± 100 kg  
Dimensions 940 x 467 x 442

